

## CBSE NCERT Solutions for Class 8 mathematics Chapter 3

### Exercise

Q.1. All rectangles are squares.

True/False

**Solution:** A rectangle is a quadrilateral that has four right angles, opposite equal sides and two sets of parallel opposite sides.

A square is a quadrilateral that has all equal sides and all angles equal to  $90^\circ$

If we compare the properties of square and rectangle, we find that both square and rectangle have all angles equal to  $90^\circ$ , parallel opposite sides but in square all sides are equal whereas in rectangle, opposite sides are equal. Hence, all rectangles are not squares.

Q.2. All rhombuses are parallelograms.

True

**Solution:** A parallelogram is a quadrilateral that has parallel and equal opposite sides and equal opposite angles.

A rhombus is a quadrilateral which has equal sides, opposite parallel sides and opposite equal angles.

Comparing the properties of square and rectangle, we get, both rhombus and parallelogram have parallel and equal opposite sides and equal opposite angles. Hence, all rhombuses are parallelograms.

False

Q.3. All squares are rhombuses and also rectangles.

True

**Solution:** We know that, a rectangle become a square when all sides of a rectangle are equal. Hence, square is a special case of rectangle. And since, square has same property as that of rhombus. Hence, all squares are rhombuses and also rectangles.

False

Q.4. All squares are not parallelograms

True/False

**Solution:** A square is a quadrilateral that has all equal sides and all angles equal to  $90^\circ$

A parallelogram is a quadrilateral that has parallel and equal opposite sides and equal opposite angles.

Since, all squares have the same property as that of parallelogram.

Hence, all squares are parallelograms.

Q.5. State whether true or false:

All kites are rhombuses.

True/False

**Solution:** A rhombus is a quadrilateral which has equal sides, opposite parallel sides and opposite equal angles.

A kite is a type of quadrilateral that has two pairs of equal length sides that join up and its diagonals meet at right angles.

In the rhombus, all sides are equal, but all kites do not have equal sides.

Hence, all kites are not rhombuses.

Q.6. All rhombuses are kites.

True

**Solution:** A kite is a type of quadrilateral that has two pairs of equal length sides that join up and its diagonals meet at right angles.

A rhombus is a quadrilateral which has equal sides, opposite parallel sides and opposite equal angles.

Since, all rhombuses have equal sides and diagonals bisect each other and, in the kite, all sides may be equal and their diagonal can also bisect each other.

Hence, all rhombuses are kites.

False

Q.7. All parallelograms are trapeziums.

True

**Solution:** We know that trapezium has only two parallel sides and since, in the parallelogram both the pairs of opposite sides are parallel to each other.  
Hence, all parallelograms are trapeziums.

False

Q.8. All squares are trapeziums.

True

**Solution:** A square is a quadrilateral that has all equal sides and all angles equal to  $90^\circ$

A trapezium is a quadrilateral with at least one pair of parallel side.

We know that a trapezium has one side parallel to each other and since, in the square two sides are parallel.  
Hence, all squares are trapeziums

False

Q.9. Identify all the quadrilaterals that have four sides of equal lengths.

**Solution:** A quadrilateral is a two-dimensional figure that has four sides, four vertices and four angles. There are many types of quadrilaterals such as square, rectangle, rhombus, parallelogram, etc.

Each type of quadrilateral has its own features.

The quadrilaterals that have four sides of equal length are rhombus and squares.

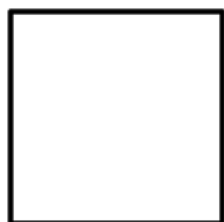
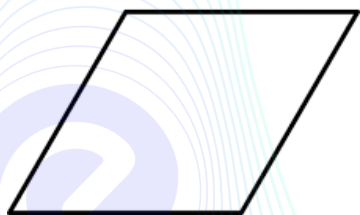

Hence, rhombus and square have sides of equal length.

Q.10. Identify all the quadrilaterals that have four right angles.

**Solution:** Quadrilateral is a two-dimensional closed figure which has four straight sides, four vertices and four angles. Quadrilaterals can be of different types such as rectangle, square, rhombus, parallelogram, trapezium and kite. Each type of quadrilateral has its own properties.

A rectangle is a quadrilateral that has four right angles, opposite equal sides and two sets of parallel opposite sides.

A square is a quadrilateral that has all equal sides and all angles equal to  $90^\circ$ . A rhombus is a quadrilateral which has equal sides, opposite parallel sides and opposite equal angles.

A parallelogram is a quadrilateral that has parallel and equal opposite sides and equal opposite angles.

A trapezium is a quadrilateral with at least one pair of parallel sides.

A kite is a type of quadrilateral that has two pairs of equal length sides that join up and its diagonals meet at right angles. Hence, from the above definitions, we can conclude that square and rectangle are the quadrilaterals that have four right angles.

Q.11. Explain how a square is a quadrilateral.

**Solution:** Quadrilateral is a two-dimensional closed figure which has four straight sides, four vertices and four angles. Quadrilaterals can be of different types such as rectangle, square, rhombus, parallelogram, trapezium and kite. Each type of quadrilateral has its own properties.

A square is a quadrilateral that has all equal sides and all angles equal to  $90^\circ$ .

We can clearly say that a square has all the properties of a quadrilateral and hence it is a quadrilateral.

Q.12. Explain how a square is a parallelogram.

**Solution:** A parallelogram is a quadrilateral that has parallel and equal opposite sides and equal opposite angles.

A square is a quadrilateral that has all equal sides and all angles equal to  $90^\circ$ .

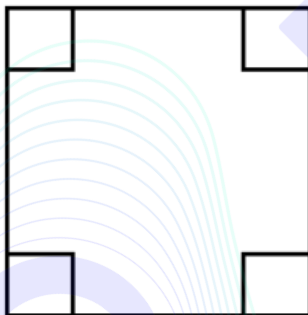

Comparing the properties of square and parallelogram, we find that both square and parallelogram have equal and parallel opposite sides and equal opposite angles. Hence, it can be said that a square is a parallelogram.

Q.13. Explain how a square is a rhombus.

**Solution:** A square is a quadrilateral that has all equal sides and all angles equal to  $90^\circ$ .

A rhombus is a quadrilateral which has equal sides, opposite parallel sides and opposite equal angles.

If we compare the properties of square with the properties of rhombus, we find that, square has equal sides like rhombus, square has opposite parallel sides like rhombus and also opposite equal angles like rhombus. Hence, it can be said that a square is a rhombus.

Q.14. Explain how a square is a rectangle.

**Solution:** A rectangle is a quadrilateral that has four right angles, opposite equal sides and two sets of parallel opposite sides.

A square is a quadrilateral that has all equal sides and all angles equal to  $90^\circ$

If we compare the properties of square and rectangle, we find that both square and rectangle have all angles equal to  $90^\circ$  and the opposite sides of square and rectangle are equal and parallel. So, it can be said that a square is a type of rectangle.

Q.15. Name the quadrilateral whose diagonals bisect each other.

**Solution:** Quadrilateral is a two-dimensional closed figure which has four straight sides, four vertices and four angles. Quadrilaterals can be of different types such as rectangle, square, rhombus, parallelogram, trapezium and kite. Each type of quadrilateral has its own properties.

A rectangle is a quadrilateral that has four right angles, opposite equal sides and two sets of parallel opposite sides. Diagonals of rectangles bisect each other.

A square is a quadrilateral that has all equal sides and all angles equal to  $90^\circ$ . Diagonals of square intersect each other at right angles. A rhombus is a quadrilateral which has equal sides, opposite parallel sides and opposite equal angles. Diagonals of rhombus perpendicularly bisect each other.

A parallelogram is a quadrilateral that has parallel and equal opposite sides and equal opposite angles. Diagonals of parallelogram bisect each other.

A trapezium is a quadrilateral with at least one pair of parallel sides.

A kite is a type of quadrilateral that has two pairs of equal length sides that join up and its diagonals meet at right angles. Hence, from the above definitions, we can conclude that square, rectangle, rhombus and parallelogram are the quadrilaterals whose diagonals bisect each other.

Q.16. Name the quadrilateral whose diagonals are perpendicular bisectors of each other.

**Solution:** Quadrilateral is a two-dimensional closed figure which has four straight sides, four vertices and four angles. Quadrilaterals can be of different types such as rectangle, square, rhombus, parallelogram, trapezium and kite. Each type of quadrilateral has its own properties.

A rectangle is a quadrilateral that has four right angles, opposite equal sides and two sets of parallel opposite sides. Diagonals of rectangles bisect each other.

A square is a quadrilateral that has all equal sides and all angles equal to  $90^\circ$ . Diagonals of square intersect each other at right angles. A rhombus is a quadrilateral which has equal sides, opposite parallel sides and opposite equal angles. Diagonals of rhombus perpendicularly bisect each other.

A parallelogram is a quadrilateral that has parallel and equal opposite sides and equal opposite angles. Diagonals of parallelogram bisect each other.

A trapezium is a quadrilateral with at least one pair of parallel sides.

A kite is a type of quadrilateral that has two pairs of equal length sides that join up and its diagonals meet at right angles. Hence, from the above definitions, we can conclude that square, rhombus and kite are the quadrilaterals whose diagonals perpendicularly bisect each other.

Q.17. Name the quadrilateral whose diagonals are equal.

**Solution:**

Quadrilateral is a two-dimensional closed figure which has four straight sides, four vertices and four angles. Quadrilaterals can be of different types such as rectangle, square, rhombus, parallelogram, trapezium and kite. Each type of quadrilateral has its own properties.

A rectangle is a quadrilateral that has four right angles, opposite equal sides and two sets of parallel opposite sides. Diagonals of rectangle are equal and intersect at right angles.

A square is a quadrilateral that has all equal sides and all angles equal to  $90^\circ$ . The diagonals of square are equal and bisect each other. A rhombus is a quadrilateral which has equal sides, opposite parallel sides and opposite equal angles.

A parallelogram is a quadrilateral that has parallel and equal opposite sides and equal opposite angles.

A trapezium is a quadrilateral with at least one pair of parallel sides.

A kite is a type of quadrilateral that has two pairs of equal length sides that join up and its diagonals meet at right angles. Hence, from the above definitions, we can conclude that square and rectangle are the quadrilaterals that have equal diagonals.

Q.18. Explain why a rectangle is a convex quadrilateral.

**Solution:**

In convex quadrilateral, all the diagonals lie inside the quadrilateral. Consider a rectangle ABCD, Its diagonal AC and BD lie inside the rectangle.

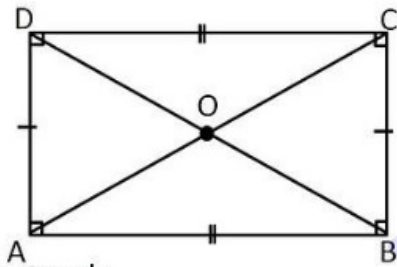

Hence, rectangle is a convex quadrilateral.

Q.19. ABC is a right-angled triangle and O is the mid-point of the side opposite to the right angle. Explain why O is equidistant from A, B and C. (The dotted lines are drawn additionally to help you.)

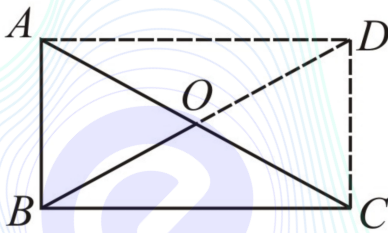

**Solution:**

Given diagram is:

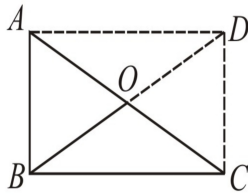

Given a right-angled triangle ABC and O is the mid-point of AC.  
 Now draw a line from A parallel to BC and from C parallel to BA.  
 Let the point of intersection of these lines be D. Now Join OD.  
 Now in quadrilateral ABCD  
 $AB \parallel DC$  and  $BC \parallel AD$   
 $\Rightarrow$  opposite sides are parallel  
 $\therefore$  ABCD is a parallelogram  
 We know that  
 Adjacent angles of a parallelogram are supplementary  
 $\angle B + \angle C = 180^\circ$   
 $\Rightarrow 90^\circ + \angle C = 180^\circ$   
 $\Rightarrow \angle C = 180^\circ - 90^\circ$   
 $\Rightarrow \angle C = 90^\circ$

Also,  
 Opposite angles of a parallelogram are equal.  
 $\angle A = \angle C$   
 $\Rightarrow \angle A = 90^\circ$   
 And  $\angle D = \angle B$   
 $\Rightarrow \angle D = 90^\circ$   
 Therefore,  
 $\angle A = \angle B = \angle C = \angle D = 90^\circ$   
 $\Rightarrow$  Each angle of ABCD is a right angle.  
 So, ABCD is a parallelogram with all angles  $90^\circ$

$\therefore$  ABCD is a rectangle  
 We know that  
 The diagonals of a rectangle bisect each other  
 $OA = OC = \frac{1}{2}AC \dots (1)$   
 $OB = OD = \frac{1}{2}BD \dots (2)$   
 Also,  
 The diagonals of a rectangle are equal in length.  
 $BD = AC$   
 Dividing both sides by 2  
 $\Rightarrow \frac{1}{2}BD = \frac{1}{2}AC$   
 $\Rightarrow OB = OA$  (from (1) and (2))  
 $\therefore OA = OB = OC$   
 Hence, O is equidistant from A, B and C.

Q.20. Classify the given figure on the basis of the following: Simple open curve / Convex polygon / Concave polygon

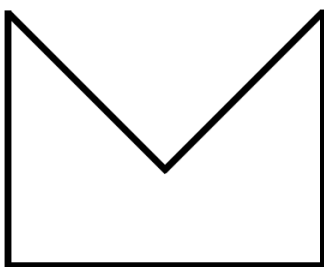

Concave Polygon

**Solution:**

The given figure is:

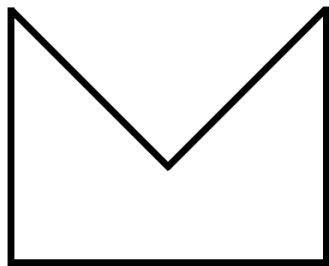

We know that, A concave polygon is defined as a polygon which has one or more interior angles greater than  $180^\circ$ . It looks like a vertex has been 'pushed in' towards the inside of the polygon. Hence, this is a concave polygon.

Q.21. Classify the given figure on the basis of the following:

Simple curve, Simple closed curve, Convex polygon, Concave polygon.

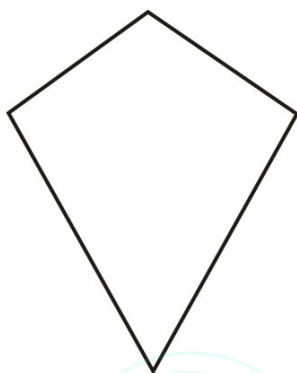

Convex polygon

**Solution:**

The given figure is:

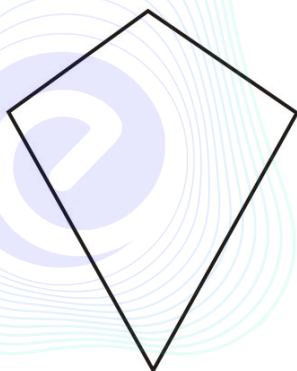

We know that, A convex polygon is a polygon with all its interior angles less than  $180^\circ$ . This means that all the vertices of the polygon will point outwards, away from the interior of the shape. Hence, this is a convex polygon.

Q.22.

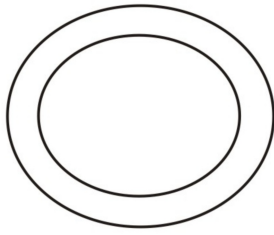

The above figure is a (simple curve / closed curve / polygon / convex polygon / concave polygon).  
closed curve

**Solution:** The given figure is,

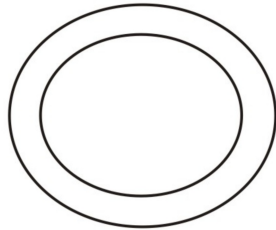

We know that, A closed curve is a connected curve that does not cross itself and ends at the same point where it begins. Examples are circles, ellipses, and polygons. Hence, the given curve is a simple closed curve.

Q.23. Identify the figure and mark the corresponding number as the answer

1 for simple curve / 2 for simple closed curve / 3 for convex polygon / 4 for concave polygon / 5 for None of these.



5



**Solution:** Simple curve is a curve that does not cross itself.

Simple closed curve is a simple curve which ends at the same point where it starts.

Convex polygon is a type of polygon where all its interior angles less than  $180^\circ$ . Concave polygon is a type of polygon where one of its angles is greater than  $180^\circ$ . The given figure is:

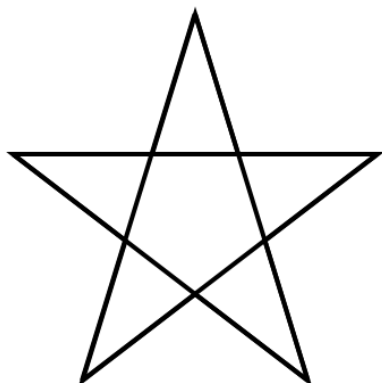

This figure does not belong to any of above-mentioned categories. So, the correct answer is none of these.

Q.24. Classify the given figure on the basis of the following:

- (i) Simple curve
- (ii) Simple closed curve
- (iii) polygon
- (iv) Convex polygon
- (v) Concave polygon

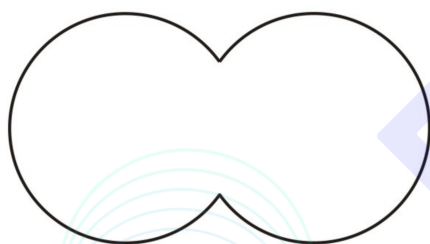

**Solution:** The given figure is:

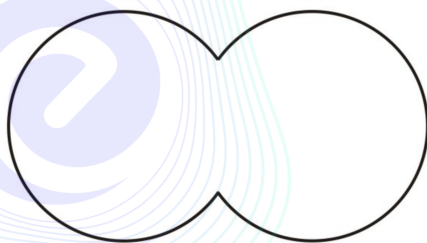

We know that, Simple Closed Curve is a connected curve that does not cross itself and ends at the same point where it begins. Examples are circles, ellipses, and polygons. Hence, this is a Simple Closed Curve.

Q.25. Classify the given figure on the basis of the following:

- (i) Simple curve
- (ii) Simple closed curve
- (iii) polygon
- (iv) Convex polygon
- (v) Concave polygon



**Solution:**

The given figure is:



We know that, Simple Closed Curve is a connected curve that does not cross itself and ends at the same point where it begins. Examples are circles, ellipses, and polygons. Hence, this is a Simple Closed Curve.

Q.26. Classify the given figure on the basis of the following:

- (i) Simple curve
- (ii) Simple closed curve
- (iii) polygon
- (iv) Convex polygon
- (v) Concave polygon

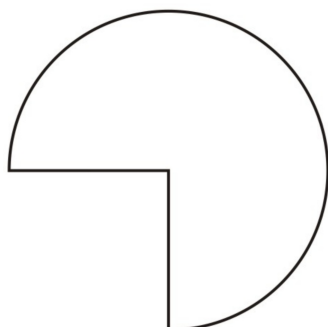

**Solution:**

The given figure is:

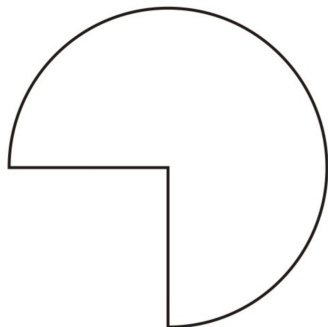

We know that, Simple Closed Curve is a connected curve that does not cross itself and ends at the same point where it begins. Examples are circles, ellipses, and polygons. Hence, this is a simple closed curve.

Q.27. Classify the given figure on the basis of the following:

- (i) Simple curve
- (ii) Simple closed curve
- (iii) polygon
- (iv) Convex polygon
- (v) Concave polygon

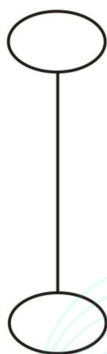
**Solution:**

The given figure is:



The figure comprises to two circles connected by a straight line. This figure will not belong to any of given categories.

Q.28. How many diagonals does a Convex quadrilateral have?

2

**Solution:** A convex quadrilateral has two diagonals.  
For e.g.

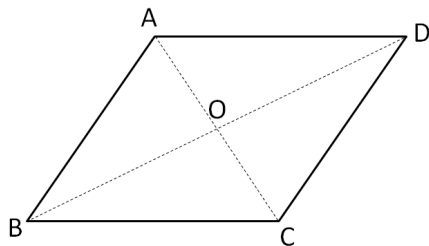

In above convex quadrilateral, AC and BD are only two diagonals.

Q.29. How many diagonals does the following figure have?

A regular hexagon.

9

**Solution:** Given, a regular hexagon.

Let us represent the number of sides as n.

Here,  $n=6$  So, number of diagonals  $=n(n-3)/2=6(6-3)/2=9$  A regular hexagon has 9 diagonals. For e.g.,

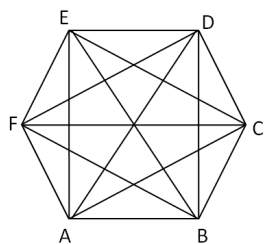

In above hexagon, diagonals are AD, AE, BD, BE, FC, FB, AC, EC and FD. So, there are total 9 diagonals in regular hexagon.

Q.30. How many diagonals does a triangle have?

0

**Solution:** To find the number of diagonals in a triangle.

We know that, number of sides in a triangle  $n=3$ .

Recall formula for finding the number of diagonals,  
number of diagonals  $=n(n-3)/2=3(3-3)/2=0$  Hence, a triangle has 0 diagonals.

Q.31. What is the sum of the measures of the angles of a convex quadrilateral? Will this property hold if the quadrilateral is not convex? (Make a non-convex quadrilateral and try!)

**Solution:**

Let ABCD be a convex quadrilateral.  
Now, draw a diagonal AC which divides the quadrilateral in two triangles.

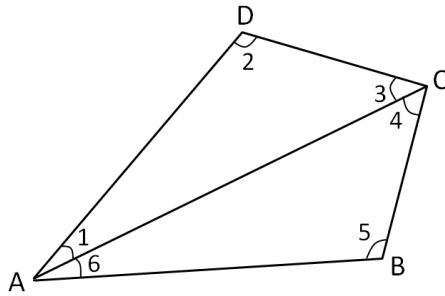

$$\begin{aligned} \angle A + \angle B + \angle C + \angle D &= \angle 1 + \angle 6 + \angle 5 + \angle 4 + \angle 3 + \angle 2 \\ &= \angle 1 + \angle 2 + \angle 3 + \angle 4 + \angle 5 + \angle 6 \\ &= 180^\circ + 180^\circ \text{ (By Angle sum property of triangle)} \\ &= 360^\circ \end{aligned}$$

Hence, the sum of measures of the triangles of a convex quadrilateral is  $360^\circ$ .

This property still holds even if the quadrilateral is not convex.

**Example:**

Let ABCD be a non-convex quadrilateral.

Now, join BD, which also divides the quadrilateral ABCD in two triangles.

Using angle sum property of triangle,

In  $\triangle ABD$ ,  $\angle 1 + \angle 2 + \angle 3 = 180^\circ$ ..... (i)

In  $\triangle BDC$ ,  $\angle 4 + \angle 5 + \angle 6 = 180^\circ$ ..... (ii)

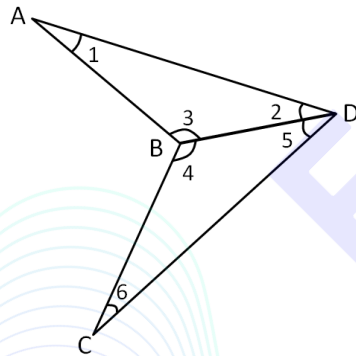

Adding equation (i) and (ii), we get

$$\begin{aligned} \angle 1 + \angle 2 + \angle 3 + \angle 4 + \angle 5 + \angle 6 &= 360^\circ \\ \Rightarrow \angle 1 + (\angle 3 + \angle 4) + \angle 6 + (\angle 2 + \angle 5) &= 360^\circ \\ \Rightarrow \angle A + \angle B + \angle C + \angle D &= 360^\circ \end{aligned}$$

Hence, the sum of measures of the triangles of a non-convex quadrilateral is also  $360^\circ$ .

Q.32. Examine the table. (Each figure is divided into triangles and the sum of the angles deduced from that.)

<b>Figure</b>				
<b>Side</b>	3	4	5	6
<b>Angle</b>	$180^\circ$	$2 \times 180^\circ$ $= (4-2) \times 180^\circ$	$3 \times 180^\circ$ $= (5-2) \times 180^\circ$	$4 \times 180^\circ$ $= (6-2) \times 180^\circ$

If the angle sum of a convex polygon with number of sides equal to 7 is  $k^\circ$ , then find the value of k.

**Solution:** When  $n=7$ , then  
 Angle sum of a polygon  $= (n-2) \times 180^\circ$   
 $= (7-2) \times 180^\circ = 5 \times 180^\circ = 900^\circ$

Hence, the value of  $k$  is 900.

Q.33. Examine the table. (Each figure is divided into triangles and the sum of the angles deduced from that.)

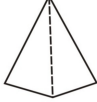
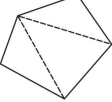
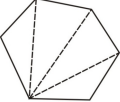
<b>Figure</b>				
<b>Side</b>	3	4	5	6
<b>Angle</b>	$180^\circ$	$2 \times 180^\circ$ $= (4-2) \times 180^\circ$	$3 \times 180^\circ$ $= (5-2) \times 180^\circ$	$4 \times 180^\circ$ $= (6-2) \times 180^\circ$

If the angle sum of a convex polygon with number of sides equal to 8 is  $k^\circ$ , then find the value of  $k$ .



1080

**Solution:** Given, sides of polygon = 8

When  $n=8$ , then  
 Angle sum of a polygon  $= (n-2) \times 180^\circ = (8-2) \times 180^\circ = 6 \times 180^\circ = 1080^\circ$

Hence, the value of  $k$  is 1080.

Q.34. Examine the table. (Each figure is divided into triangles and the sum of the angles deduced from that.)

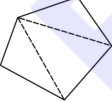
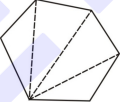
<b>Figure</b>				
<b>Side</b>	3	4	5	6
<b>Angle</b>	$180^\circ$	$2 \times 180^\circ$ $= (4-2) \times 180^\circ$	$3 \times 180^\circ$ $= (5-2) \times 180^\circ$	$4 \times 180^\circ$ $= (6-2) \times 180^\circ$

If the angle sum of a convex polygon with number of sides equal to 10 is  $k^\circ$ , then find the value of  $k$ .

1440

**Solution:** Given, number of sides of polygon = 10

When  $n=10$ , then  
 Angle sum of a polygon  $= (n-2) \times 180^\circ = (10-2) \times 180^\circ = 8 \times 180^\circ = 1440^\circ$

Hence, the value of  $k$  is 1440.

Q.35. Examine the table. Examine the table. (Each figure is divided into triangles and the sum of the angles deduced from that.)

<b>Figure</b>				
<b>Side</b>	3	4	5	6
<b>Angle</b>	$180^\circ$	$2 \times 180^\circ$ $= (4-2) \times 180^\circ$	$3 \times 180^\circ$ $= (5-2) \times 180^\circ$	$4 \times 180^\circ$ $= (6-2) \times 180^\circ$

180 If the angle sum of a convex polygon with number of sides equal to n is  $n-2 \times k^\circ$ , find the value of k.

**Solution:**

We know that,

A quadrilateral with n sides can be divided in to n-2 triangles.

So, the sum of interior angles of a quadrilateral =  $n-2 \times$  sum of interior angles of a triangle =  $(n-2) \times 180^\circ$ . Hence, the value of  $k=180^\circ$ .

Q.36. What is a regular polygon? State the name of a regular polygon of 3 sides.

**Solution:**

A regular polygon has all sides of equal length and the interior angles of equal measurement.

Example: Square

Regular polygon of 3 sides is an Equilateral Triangle.

Q.37. What is a regular polygon? State the name of a regular polygon of 4 sides.

**Solution:**

A regular polygon has all sides of equal length and the interior angles of equal measurement.

Consider the figure below,

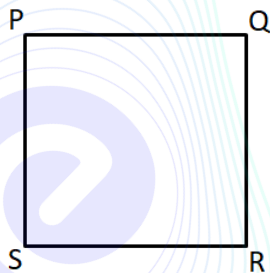

Here, all the sides and angle are equal. Hence, a regular polygon having four sides is called a square.

Q.38. What is a regular polygon? State the name of a regular polygon of 6 sides.

**Solution:**

We know that,

A regular polygon has all sides of equal length and the interior angles of equal measurement.

Consider the figure below,

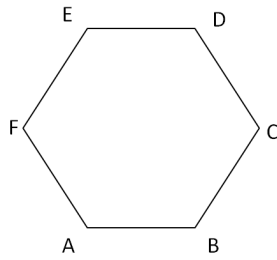

This is a six sided regular polygon with all sides and angles equal. Hence, a regular polygon having six sides is called a hexagon.

Q.39. Find the angle measure of  $x$  in the given figure.

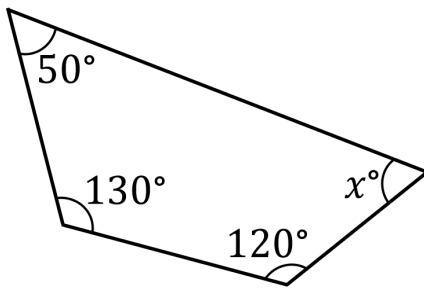

60

**Solution:**

Given figure is

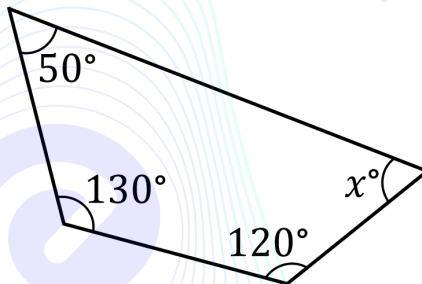

We know that in any quadrilateral, the sum of interior angles will be  $360^\circ$ .

So, we can write as  $50^\circ + 130^\circ + 120^\circ + x = 360^\circ$  (Angle sum Property of a quadrilateral)

$$\Rightarrow 300^\circ + x = 360^\circ$$

$$\Rightarrow x = 360^\circ - 300^\circ$$

$$\Rightarrow x = 60^\circ$$

Therefore, the value of  $x$  is 60.



Q.40. Find the value of  $x$  in the given figure.

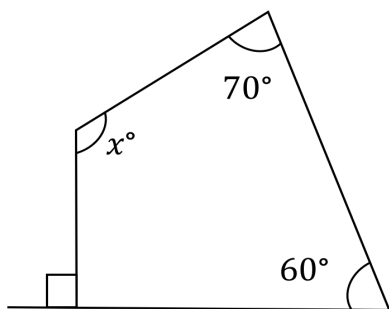

140

**Solution:** Given figure is:

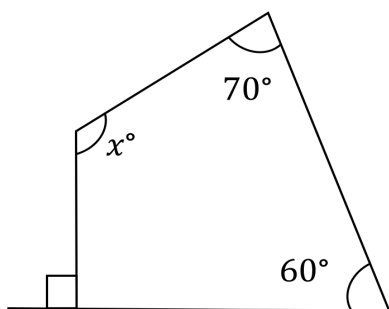

We know in any quadrilateral, sum of interior angles will be  $360^\circ$ . Hence, we can write as  $90^\circ + 60^\circ + 70^\circ + x^\circ = 360^\circ$  (Angle sum property of a quadrilateral)  $\Rightarrow 220^\circ + x^\circ = 360^\circ \Rightarrow x^\circ = 360^\circ - 220^\circ \Rightarrow x^\circ = 140^\circ$   
Hence, the value of  $x = 140$ .

Q.41. The angle measure in the given figure is  $x^\circ$ . Find the value of  $x$ .

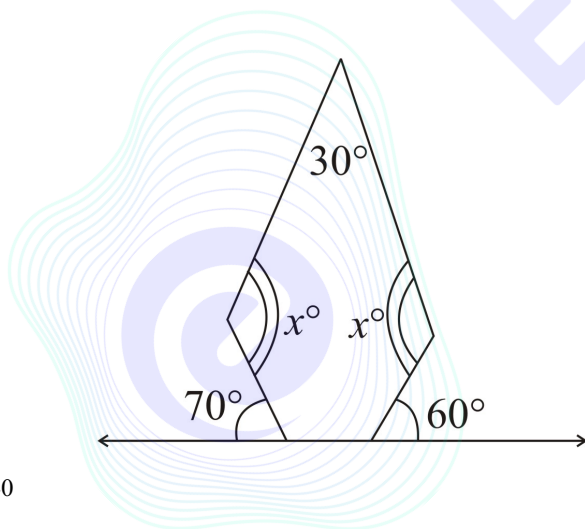

140

**Solution:** Given figure is,

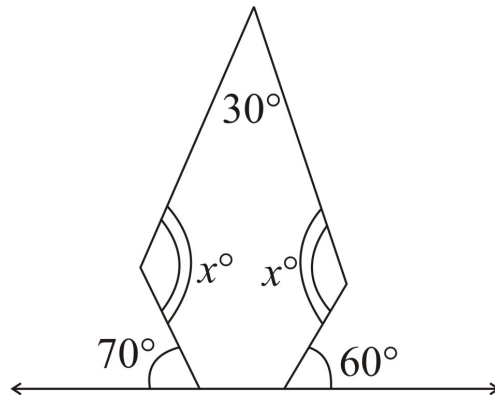

First base interior angle  $\angle 1 = 180^\circ - 70^\circ = 110^\circ$  (Linear pair)

Second base interior angle  $\angle 2 = 180^\circ - 60^\circ = 120^\circ$  (Linear pair) Here, the total number of sides is 5. Therefore,  $n=5$ . We know that, angle sum of a polygon  $= (n-2) \times 180^\circ = (5-2) \times 180^\circ = 3 \times 180^\circ = 540^\circ$

Now, we can write:

$$30^\circ + x^\circ + 110^\circ + 120^\circ + x^\circ = 540^\circ$$

$$\Rightarrow 260^\circ + 2x^\circ = 540^\circ \Rightarrow 2x^\circ = 540^\circ - 260^\circ \Rightarrow 2x^\circ = 280^\circ \Rightarrow x^\circ = 140^\circ$$

Therefore, the value of  $x$  is 140.

Q.42. If each angle in the given figure, measure  $x^\circ$ , then find the value of  $x$ .

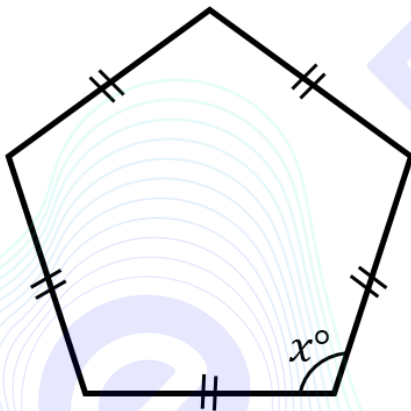

108

**Solution:** Given,

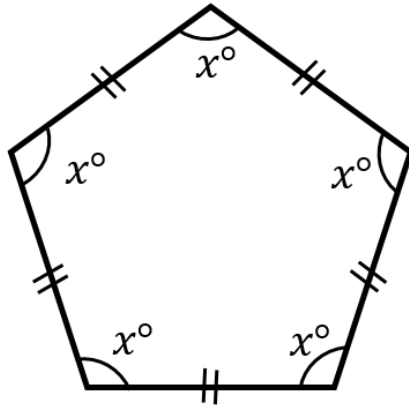

Here, the total number of sides = 5.

Therefore,  $n=5$ . We know that Angle sum of a polygon  $=n-2 \times 180^\circ = 5-2 \times 180^\circ = 3 \times 180^\circ = 540^\circ$  We can write,  $x^\circ+x^\circ+x^\circ+x^\circ+x^\circ=540^\circ \Rightarrow 5x^\circ=540^\circ \Rightarrow x^\circ=108^\circ$  Hence, the value of  $x=108$ .

Q.43. From the figure, if  $x+y+z=k^\circ$  then the value of  $k$  is

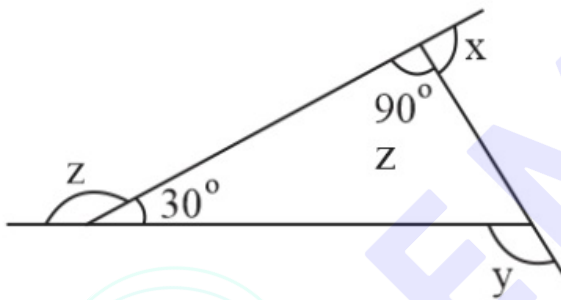

360

**Solution:** The given figure is:

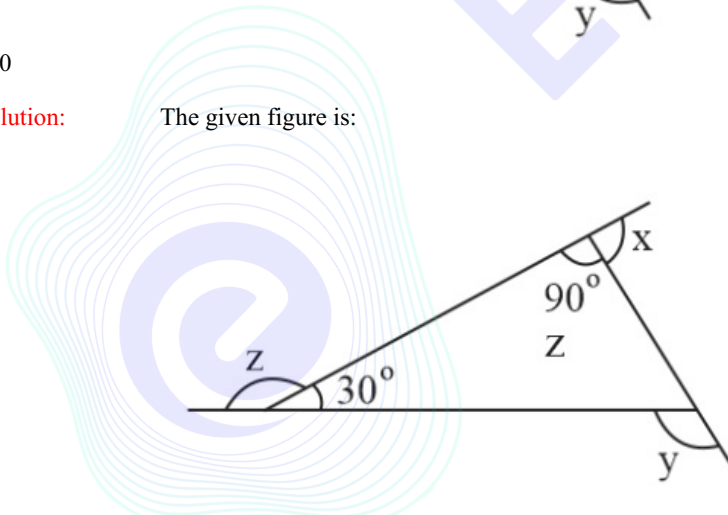

$90^\circ+x=180^\circ$  (Linear pair of angles)

$\Rightarrow x=180^\circ-90^\circ=90^\circ$   $z+30^\circ=180^\circ$  (Linear pair of angles)  $\Rightarrow z=180^\circ-30^\circ=150^\circ$   $y=90^\circ+30^\circ=120^\circ$  (Exterior angle property) Now,  $x+y+z=90^\circ+120^\circ+150^\circ=360^\circ=k^\circ$  Hence,  $k=360$

Q.44. If  $x+y+z+w=k^\circ$  then the value of  $k$  is

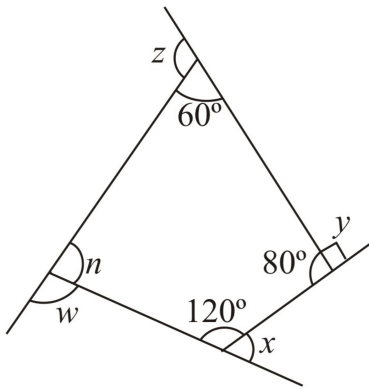

360

**Solution:**

Given figure is:

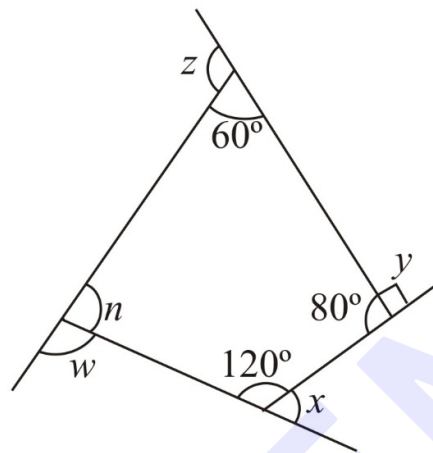

From the Angle Sum Property of Quadrilateral, we can write  $60^\circ+80^\circ+120^\circ+n=360^\circ$

$$\Rightarrow 260^\circ+n=360^\circ \Rightarrow n=360^\circ-260^\circ \Rightarrow n=100^\circ$$

$$w+100^\circ=180^\circ \quad \dots \text{Linear pair}$$

$$w=180^\circ-100^\circ=80^\circ \quad \dots 1$$

$$x+120^\circ=180^\circ \quad \dots \text{Linear pair} \quad x=180^\circ-120^\circ=60^\circ \quad \dots 2 \quad y+80^\circ=180^\circ \quad \dots \text{Linear pair} \quad y=180^\circ-80^\circ=100^\circ \quad \dots 3$$

$$z+60^\circ=180^\circ \quad \dots \text{Linear pair} \quad z=180^\circ-60^\circ=120^\circ \quad \dots 4 \quad \text{On adding equations, 1,2,3 and 4}$$

$$x+y+z+w=100^\circ+120^\circ+80^\circ+60^\circ \Rightarrow x+y+z+w=360^\circ=k^\circ \quad \text{Hence, } k=360$$

Q.45. Find  $x$  in the given figure:

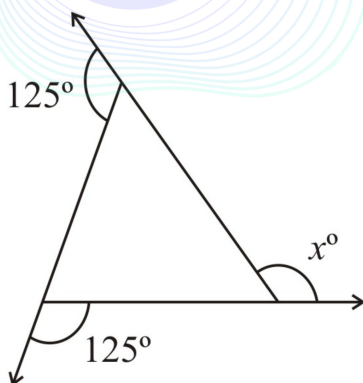

110

**Solution:**

Given figure is:

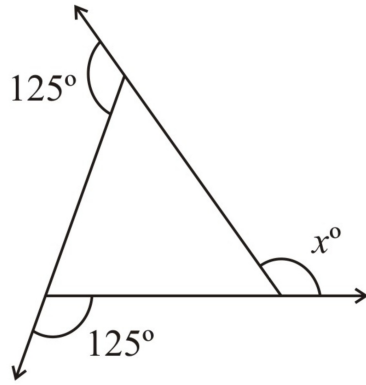

$$\Rightarrow x + 125^\circ + 125^\circ = 360^\circ \text{ (The sum of exterior angles in a polygon is always equal to } 360^\circ\text{)}$$

$$\Rightarrow x + 250^\circ = 360^\circ \Rightarrow x = 360^\circ - 250^\circ \Rightarrow x = 110^\circ \text{ Therefore, the value of } x \text{ is } 110^\circ.$$

Q.46. If  $x = k^\circ$  in the given figure then the value of  $k$  is

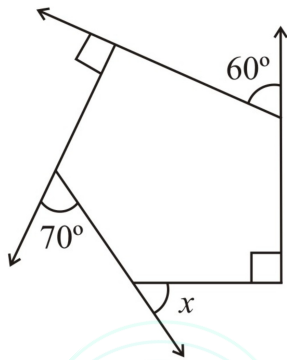

50

EMBIBE

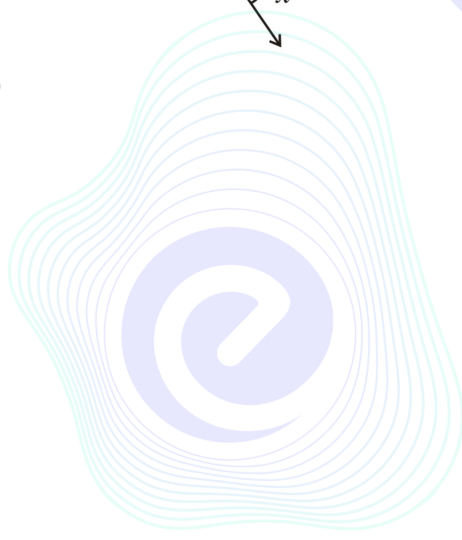

**Solution:**

The given figure is:

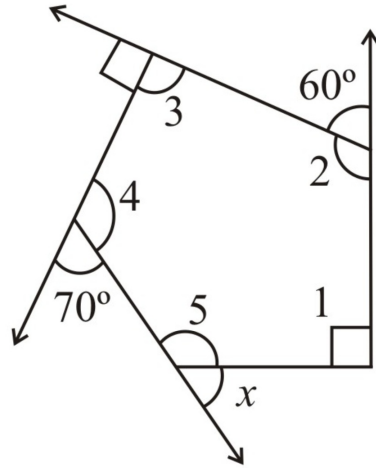

Given polygon has 5 sides.

Therefore,  $n=5$

We know that sum of angles of a polygon  $=n-2 \times 180^\circ = 5-2 \times 180^\circ = 3 \times 180^\circ = 540^\circ$

We know that the sum of linear pair angles  $=180^\circ$

$$\angle 1 + 90^\circ = 180^\circ$$

$$\angle 1 = 180^\circ - 90^\circ = 90^\circ \dots(i) \text{ Similarly, } \angle 2 + 60^\circ = 180^\circ \angle 2 = 180^\circ - 60^\circ = 120^\circ \dots(ii)$$

$$\text{Similarly, } \angle 3 + 90^\circ = 180^\circ \angle 3 = 180^\circ - 90^\circ = 90^\circ \dots(iii)$$

$$\text{Similarly, } \angle 4 + 70^\circ = 180^\circ \angle 4 = 180^\circ - 70^\circ = 110^\circ \dots(iv)$$

On adding equations (i), (ii), (iii) and (iv), we get

$$\angle 1 + \angle 2 + \angle 3 + \angle 4 + \angle 5 = 540^\circ$$

$$\Rightarrow 90^\circ + 120^\circ + 90^\circ + 110^\circ + \angle 5 = 540^\circ \Rightarrow \angle 5 = 540^\circ - 410^\circ \Rightarrow \angle 5 = 130^\circ \text{ Now, using the linear pair of angles. } x + 130^\circ = 180^\circ \Rightarrow x = 180^\circ - 130^\circ = 50^\circ = k^\circ \text{ Therefore, } k=50$$

Q.47. The measure of each exterior angle of a regular polygon of 9 sides is  $x^\circ$ , find the value of  $x$ .  
40

**Solution:**

It is given that the number of sides  $=9$

That is,  $n=9$ .

We know that sum of angles of a regular polygon  $=n-2 \times 180^\circ = 9-2 \times 180^\circ = 7 \times 180^\circ = 1260^\circ$  Each interior angle  $=\frac{\text{Sum of interior angles}}{\text{Number of sides}} = \frac{1260^\circ}{9} = 140^\circ$  Each exterior angle  $x^\circ = 180^\circ - 140^\circ = 40^\circ$  (Using linear pair) Therefore, the value of  $x$  is 40.

Q.48. If the measure of each exterior angle of a regular polygon of 15 sides is  $k^\circ$  then the value of  $k$  is  
24

**Solution:**

It is given that number of sides,  $n=15$ .

We know that sum of exterior angles of a regular polygon  $=360^\circ$

Each exterior angle  $=\frac{\text{Sum of exterior angles}}{\text{Number of sides}} = \frac{360^\circ}{15} = 24^\circ = k^\circ$  Therefore,  $k=24$

Q.49. How many sides does a regular polygon have, if the measure of an exterior angle is  $24^\circ$ ?  
15

**Solution:** We know that sum of exterior angles of a regular polygon =  $360^\circ$   
 Number of sides =  $\frac{\text{Sum of exterior angles}}{\text{Each exterior angle}} = \frac{360^\circ}{24^\circ} = 15$   
 Hence, the regular polygon has 15 sides.

Q.50. How many sides does a regular polygon have if each of its interior angles is  $165^\circ$ ?  
 24

**Solution:** Given interior angle is  $165^\circ$   
 Exterior angle =  $180^\circ - 165^\circ = 15^\circ$   
 We know that sum of exterior angles of a regular polygon =  $360^\circ$  Number of sides  
 =  $\frac{\text{Sum of exterior angles}}{\text{Each exterior angle}} = \frac{360^\circ}{15^\circ} = 24$  Hence, the regular polygon has 24 sides.

Q.51. Is it possible to have a regular polygon with of each exterior angle as  $22^\circ$ ?

**Solution:** Given, exterior angle is  $22^\circ$ .  
 So, the number of sides =  $\frac{\text{Total measure of all exterior angle}}{\text{exterior angle}} = \frac{360^\circ}{22^\circ} = 16.36$   
 Here, number of sides is not a whole number. Therefore, it is not possible to have a regular polygon with each exterior angles as  $22^\circ$ .

Q.52. Can  $22^\circ$  be an interior angle of a regular polygon? Why?

**Solution:** Let us consider that the interior angle of a regular polygon is  $22^\circ$ .  
 We know, Exterior Angle =  $180^\circ - \text{Interior Angle}$ . (Using the linear pair of angles)  
 Exterior Angle =  $180^\circ - 22^\circ = 158^\circ$ . Number of sides of a regular polygon =  $\frac{360^\circ}{\text{Exterior angle}}$  Here, the number of sides of the regular polygon =  $\frac{360^\circ}{158^\circ} = 2.27$ , which is not a whole number. Hence, it is not possible to have a regular polygon with each interior angle as  $22^\circ$ .

Q.53. What is the minimum interior angle possible for a regular polygon? Why?

**Solution:** The minimum number of sides a regular polygon can have is 3.  
 So, the equilateral triangle being a regular polygon of 3 sides have the least measure of an interior angle.  
 Let each angle of equilateral triangle =  $x$  So, we can write  $x+x+x=180^\circ$  (By angle sum Property)  $\Rightarrow 3x=180^\circ$   
 $\Rightarrow x=60^\circ$  So, the minimum interior angle possible for a regular polygon will be  $60^\circ$ .

Q.54. If the maximum exterior angle possible for a regular polygon is  $A^\circ$ , then find the value of A.  
 120

**Solution:** We know that,  
 Less the interior angle more will be the value of the exterior angle.  
 Also, an equilateral triangle has the least measure of an interior angle equal to  $60^\circ$ . And,  
 exterior angle =  $180^\circ - \text{interior angle}$  (using linear pair) Therefore, the greatest exterior angle possible =  $180^\circ - 60^\circ = 120^\circ$ .

Q.55. Given a parallelogram ABCD. Complete the statement along with the definition or property used.

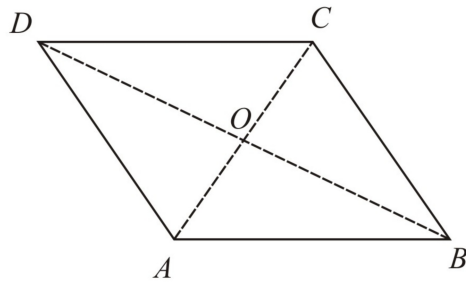

AD= \_\_\_\_\_

**Solution:** Given a parallelogram ABCD.

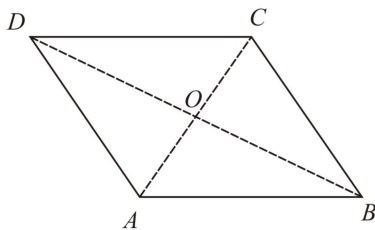

We know that the opposite sides of a parallelogram are equal. Here, AD and BC are the opposite sides of the parallelogram. Therefore,  $AD=BC$ .

Q.56. Given a parallelogram ABCD. Complete the statement along with the definition or property used.

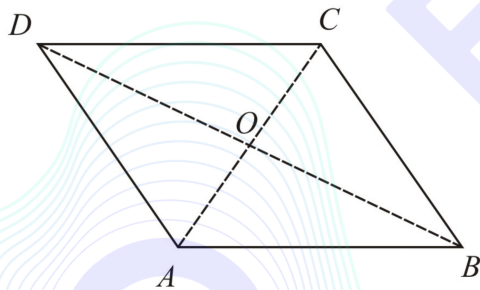

$\angle DCB=$  \_\_\_\_\_.

**Solution:** Let us recall the properties related to angles of a parallelogram.

The sum of adjacent angles is supplementary and opposite angles are equal.

Therefore,  $\angle DCB=\angle DAB$ .



Q.57. Given a parallelogram ABCD. Complete the statement along with the definition of the property used.

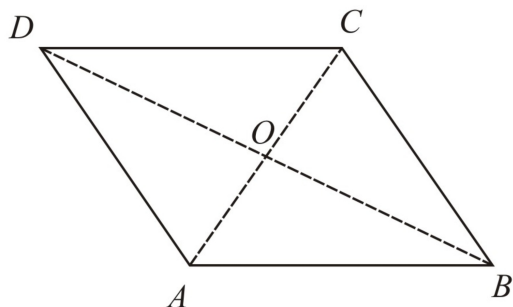

OC=\_\_\_\_\_.

**Solution:** For the given parallelogram ABCD, AC and BD are diagonals of the parallelogram.  
 We know that diagonals of a parallelogram bisect each other.  
 Hence,  $OC=OA$ .

Q.58. Give a parallelogram ABCD. Complete the statement along with the definition or property used.

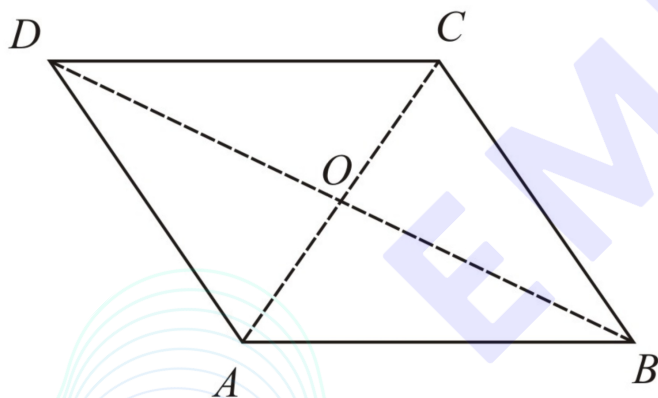

$m\angle DAB+m\angle CDA=$ \_\_\_\_\_.

**Solution:** We know that,  
 Adjacent angles in a parallelogram are supplementary.  
 Here,  $\angle DAB$  and  $\angle CDA$  are adjacent angles. Therefore,  $\angle DAB+\angle CDA=180^\circ$ .

Q.59. Explain how this figure is a trapezium. Which of its two sides are parallel?

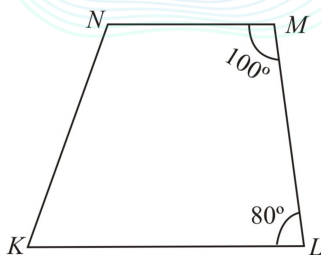

**Solution:**

Given diagram is:

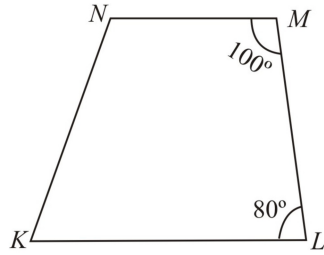

Quadrilateral KLMN having  $\angle L=80^\circ$  and  $\angle M=100^\circ$ .  
Now extend the line LM to O as shown in figure

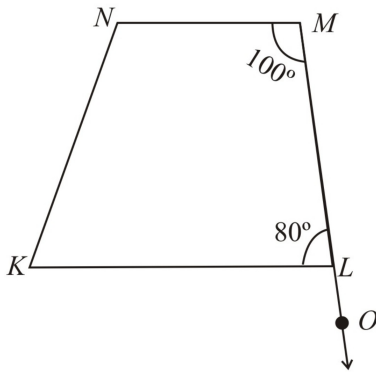

For the line segment NM and KL, with MO is a transversal.  
Now  $\angle L + \angle M = 180^\circ$   
Thus, sum of interior angles on the same side of transversal is  $180^\circ$  which is only possible if NM and KL are parallel lines.  
Therefore,  $NM \parallel KL$   
Since, KLMN is quadrilateral with  $KL \parallel NM$   
 $\therefore$  KLMN is a trapezium

Q.60. Find  $m\angle C$  in figure, if  $AB \parallel DC$  {write only numerical value without degrees symbol}

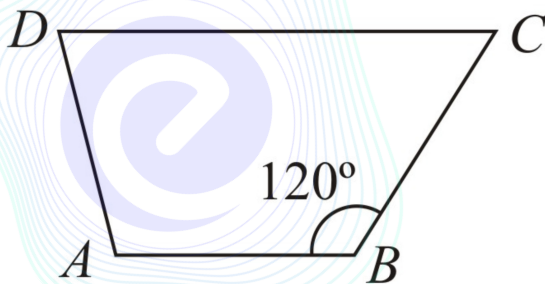

60

**Solution:**Given:  $AB \parallel DC$ 

Hence, it is a trapezium

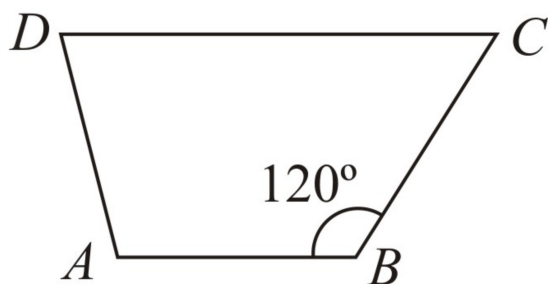
To find:  $m\angle C$ Here,  $AB \parallel DC$ Clearly,  $\angle B + \angle C = 180^\circ$  (A Pair of adjacent angles in a trapezium are supplementary)

$$\Rightarrow 120^\circ + m\angle C = 180^\circ$$

$$\Rightarrow m\angle C = 180^\circ - 120^\circ = 60^\circ$$

Hence,  $m\angle C = 60^\circ$ 

Q.61. Find the measure of  $\angle P$  and  $\angle S$  if  $SP \parallel QR$  in given figure. (If you find  $m\angle R$ , is there more than one method to find  $m\angle P$ )

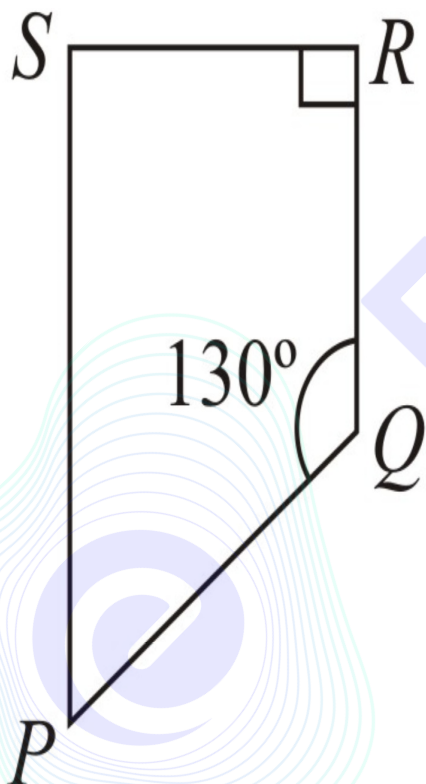

**Solution:**

Given:

SPQR

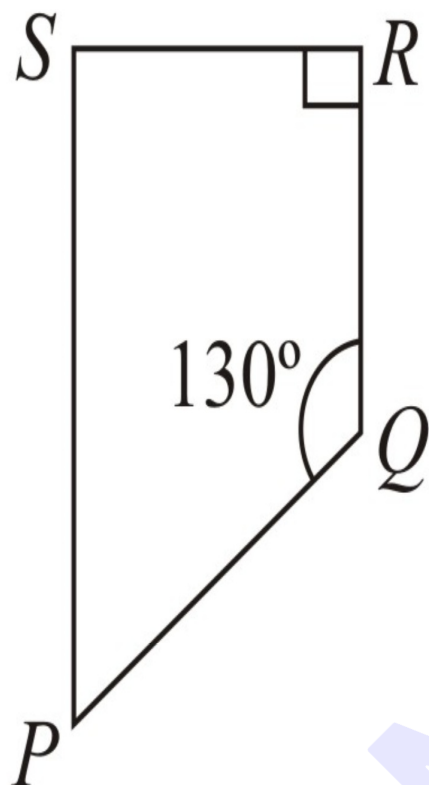
Hence, SR and PQ are transversals from the diagram To find:  $m\angle P$  and  $m\angle S$ 

$$\angle P + \angle Q = 180^\circ \quad (\because \text{Sum of co-interior angles is } 180^\circ)$$

$$\Rightarrow \angle P + 130^\circ = 180^\circ$$

$$\Rightarrow \angle P = 180^\circ - 130^\circ$$

$$\Rightarrow \angle P = 50^\circ$$

$$\text{And } \angle S + \angle R = 180^\circ \quad (\because \text{Sum of co-interior angles is } 180^\circ)$$

$$\Rightarrow \angle S + 90^\circ = 180^\circ \quad (\angle R = 90^\circ \text{ (given)})$$

$$\Rightarrow \angle S = 180^\circ - 90^\circ$$

$$\Rightarrow \angle S = 90^\circ$$

Yes, there is one more method to find  $\angle P$ .

In quadrilateral SRQP

$$\angle S + \angle R + \angle Q + \angle P = 360^\circ \quad (\text{Angle sum property of quadrilateral})$$

$$\Rightarrow 90^\circ + 90^\circ + 130^\circ + \angle P = 360^\circ$$

$$\Rightarrow 310^\circ + \angle P = 360^\circ$$

$$\Rightarrow \angle P = 360^\circ - 310^\circ$$

$$\Rightarrow \angle P = 50^\circ$$

Q.62. Consider the following parallelogram. Find the values of the unknowns  $x, y, z$ .

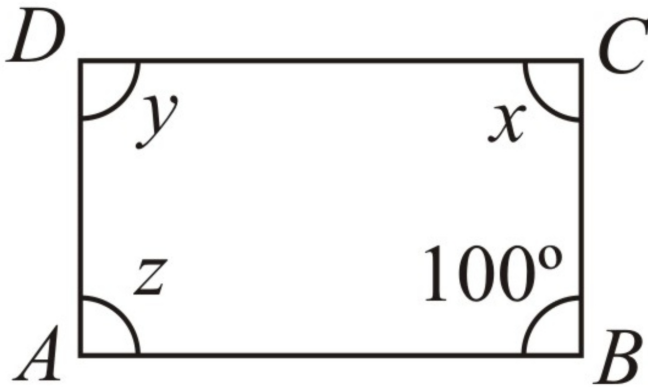

**Solution:** Given parallelogram is:

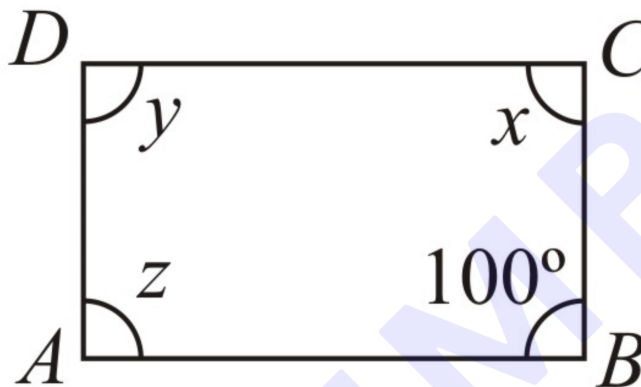

Here,  $\angle B = 100^\circ$ .

In parallelogram ABCD, adjacent angles are supplementary.

Hence,  $\angle B + \angle C = 180^\circ$

$\Rightarrow 100^\circ + x = 180^\circ$

$\Rightarrow x = 180^\circ - 100^\circ = 80^\circ$

Opposite angles of a parallelogram are equal.

Hence,  $z = x = 80^\circ$

Similarly,  $y = \angle B = 100^\circ$

Therefore,  $x = z = 80^\circ$  and  $y = 100^\circ$ .

Q.63. The value of  $x + y + z$  is  $\theta^\circ$ , find the value of  $\theta$ .

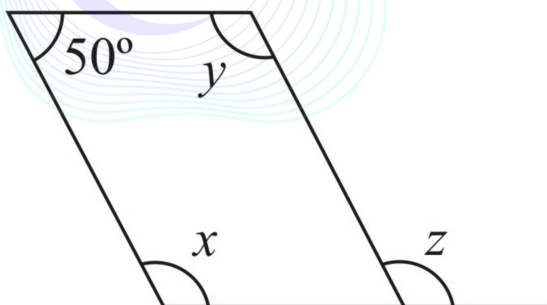

390

**Solution:**

Given,

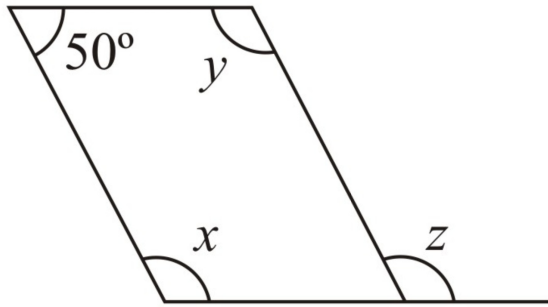

$$x + 50^\circ = 180^\circ \quad (\because \text{Sum of adjacent angles in a parallelogram is } 180^\circ)$$

$$\Rightarrow x = 180^\circ - 50^\circ = 130^\circ$$

Also,  $x = y = 130^\circ$  ( $\because$  Opposite angles of a parallelogram are equal) and  $z = x = 130^\circ$  ( $\because$  Corresponding angles are equal) Hence,  $\theta = x + z + y = 130^\circ + 130^\circ + 130^\circ \Rightarrow \theta = 390^\circ$  Thus, the value of  $\theta = 390^\circ$ .

Q.64. Consider the following parallelogram. Find the values of the unknowns  $x, y, z$ .

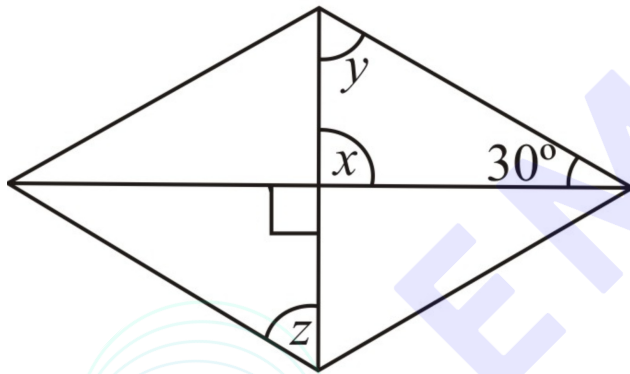

**Solution:**

Given parallelogram is:

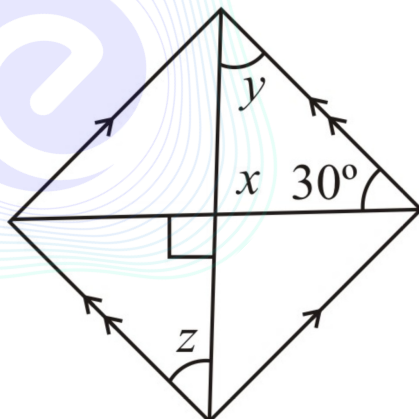

$$x = 90^\circ \quad (\because \text{Vertically opposite angles are equal})$$

$$\text{And } y + x + 30^\circ = 180^\circ \quad (\text{Angle sum property of a triangle})$$

$$\Rightarrow y + 90^\circ + 30^\circ = 180^\circ \Rightarrow y + 120^\circ = 180^\circ \Rightarrow y = 180^\circ - 120^\circ = 60^\circ \text{ and } z = y = 60^\circ \quad (\because \text{Alternate angles are equal})$$

Hence,  $x = 90^\circ$  and  $z = y = 60^\circ$ .

Q.65. Consider the following parallelogram. Find the values of the unknowns  $x, y, z$ .

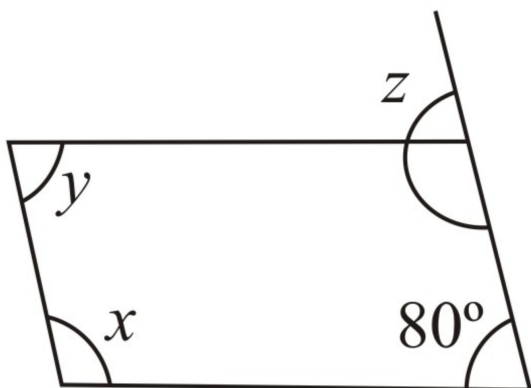

**Solution:** Given parallelogram is:

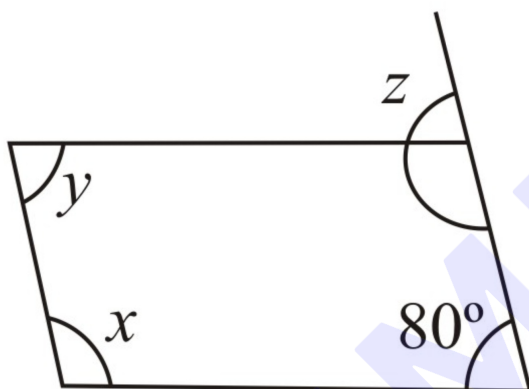

$z = 80^\circ$  ( $\because$  Corresponding angles are equal)  
 And  $x + 80^\circ = 180^\circ$  ( $\because$  Sum of adjacent angles in a parallelogram is  $180^\circ$ )  
 $\Rightarrow x = 180^\circ - 80^\circ = 100^\circ$   
 and  $y = 80^\circ$  ( $\because$  Opposite angles of a parallelogram are equal)  
 Hence,  $x = 100^\circ, y = z = 80^\circ$ .

Q.66. Consider the following parallelogram. Find the values of the unknowns  $x, y, z$ .

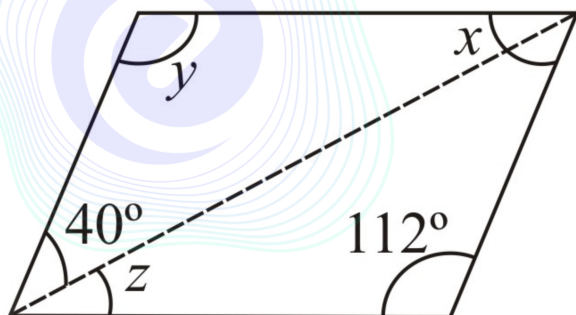

**Solution:** Given Parallelogram is:

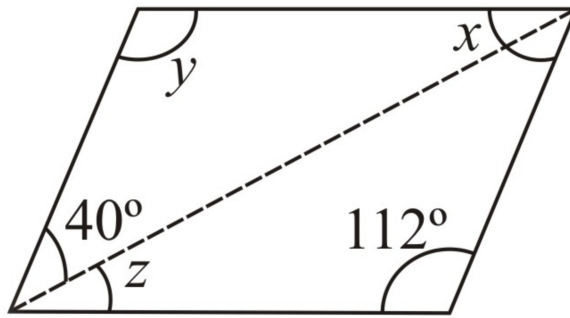

$y = 112^\circ$  ( $\because$  Opposite angles of a parallelogram are equal)  
 $40^\circ + y + x = 180^\circ$  ( $\because$  Angle sum property of a triangle)  
 $\Rightarrow 40^\circ + 112^\circ + x = 180^\circ$   
 $\Rightarrow 152^\circ + x = 180^\circ$   
 $\Rightarrow x = 180^\circ - 152^\circ = 28^\circ$   
 and  $z = x = 28^\circ$  ( $\because$  Alternate angles are equal)  
 Hence,  $x = z = 28^\circ$  and  $y = 112^\circ$ .

Q.67. Can a quadrilateral ABCD be a parallelogram, if:  $\angle D + \angle B = 180^\circ$ ?

**Solution:** Given,  $\angle D + \angle B = 180^\circ$

Let us consider a parallelogram ABCD as shown below:

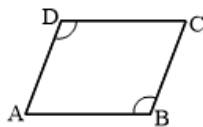

Given that,  $\angle D + \angle B = 180^\circ$   
 If ABCD is a parallelogram then opposite angles should be equal.  
 Given,  $\angle D + \angle B = 180^\circ$   
 $\Rightarrow \angle B + \angle B = 180^\circ$   
 $\Rightarrow 2\angle B = 180^\circ$   
 $\Rightarrow \angle B = 90^\circ$   
 $\therefore \angle D = \angle B = 90^\circ$

Similarly,  $\angle A = \angle C = 90^\circ$  If all the angles are  $90^\circ$ , it can be a square or a rectangle. So, yes it can be parallelogram only if the quadrilateral is rectangle or square.

Q.68. Can a quadrilateral ABCD be a parallelogram, if  $AB = DC = 8\text{cm}$ ,  $AD = 4\text{cm}$  and  $BC = 4.4\text{cm}$ ?

**Solution:** Given that,

$AB = DC = 8\text{cm}$ ,  $AD = 4\text{cm}$  and  $BC = 4.4\text{cm}$ .

We know that the opposite sides of a parallelogram are equal.

Here,  $AB = DC$  and  $AD \neq BC$

Hence, ABCD is not a parallelogram.

Q.69. Can a quadrilateral ABCD be a parallelogram if  $\angle A = 70^\circ$  and  $\angle C = 65^\circ$ ?

**Solution:** Given, a quadrilateral ABCD  
 $\angle A = 70^\circ$  and  $\angle C = 65^\circ$ .

Here,  $\angle A \neq \angle C$

Hence, ABCD is not a parallelogram because we know that opposite angles of parallelogram are equal.

Q.70. Draw a rough figure of a quadrilateral that is not a parallelogram but has exactly two opposite angles of equal measures.



**Solution:** The rough diagram of a quadrilateral is shown below:

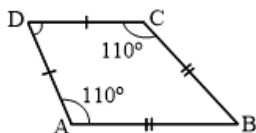

ABCD is quadrilateral in which angles  $\angle A = \angle C = 110^\circ$  which is in the shape of kite. Hence, ABCD is a quadrilateral that is not a parallelogram but has exactly two opposite angles of equal measures.

Q.71. The measure of two adjacent angles of a parallelogram are in the ratio 3:2. If the measure of  $\angle D = 3x^\circ$ , find the value of  $3x$ .  
108

**Solution:**

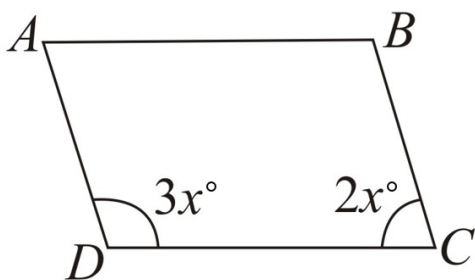

ABCD be the given parallelogram and  $\angle D = 3x^\circ$ .

Let  $\angle C = 2x$ .

Since the adjacent angles in a parallelogram are supplementary.

$$\therefore 3x + 2x = 180^\circ$$

$$\Rightarrow 5x = 180^\circ$$

$$\Rightarrow x^\circ = 180^\circ \div 5 = 36^\circ$$

$$\text{and } \angle D = 3x^\circ = 3 \times 36^\circ = 108^\circ.$$

Hence, the value of  $3x = 108$ .

Q.72. Two adjacent angles of a parallelogram have equal measure. Find the measure of the angles of the parallelogram. {write only numerical value without degrees symbol}

90

**Solution:** Given -Two adjacent angles of a parallelogram have equal measure .

Let each adjacent angle be  $x$ .

Since, the adjacent angles in a parallelogram are supplementary.

$$x + x = 180^\circ$$

$$\Rightarrow 2x = 180^\circ$$

$$\Rightarrow x = 180^\circ \div 2 = 90^\circ$$

Now, let us recall the angle properties of parallelogram, and we will find that measure of each angle is  $90^\circ$ .

Q.73. The adjacent figure HOPE is a parallelogram. Find the angle measures  $x$ ,  $y$  and  $z$ . State the properties you use to find them.

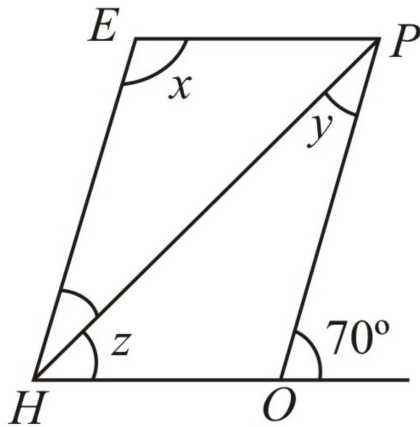

**Solution:** Given parallelogram is:

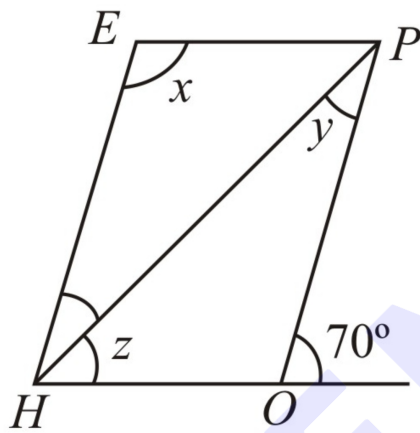

Here,  $\angle HOP + 70^\circ = 180^\circ$  ( $\because$  sum of angles of linear pair is  $180^\circ$ )  
 $\Rightarrow \angle HOP = 180^\circ - 70^\circ = 110^\circ$   
 and  $\angle E = \angle HOP$  ( $\because$  Opposite angles of a parallelogram are equal)  
 $\Rightarrow x = 110^\circ$   
 Now,  $\angle PHE = \angle HPO$  ( $\because$  Alternate angles are equal)  
 $\therefore y = 40^\circ$

Since,  $OP \parallel HE$   
 Therefore,  $\angle EHO = \angle O = 70^\circ$  (Corresponding angles)  
 Since,  $\angle EHO = 70^\circ$   
 $\Rightarrow 40^\circ + z = 70^\circ$   
 $\Rightarrow z = 70^\circ - 40^\circ = 30^\circ$   
 Hence,  $x = 110^\circ$ ,  $y = 40^\circ$  and  $z = 30^\circ$ .

Q.74. The following figure GUNS is a parallelogram, Find  $x$  and  $y$ . (Lengths are in cm)

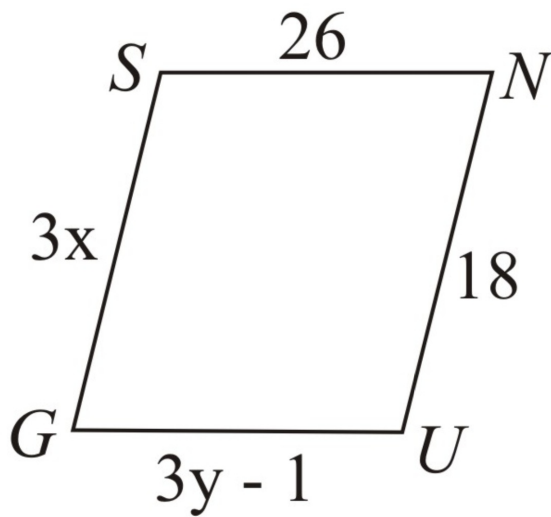

**Solution:**

Given parallelogram is:

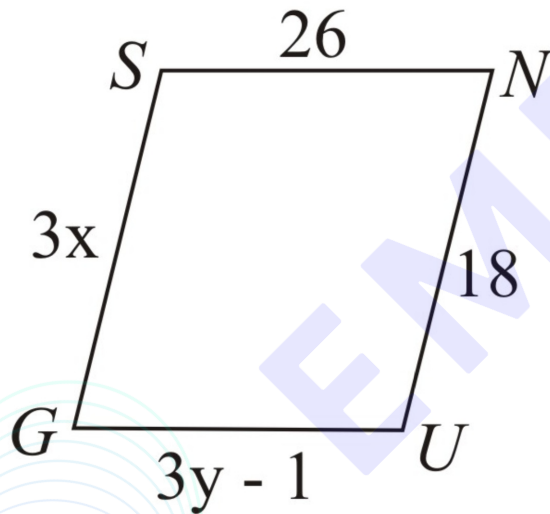

In parallelogram GUNS,  
 $GS=UN$  ( $\because$  Opposite sides of parallelogram are equal)  
 $\Rightarrow 3x=18$   
 $\Rightarrow x=18 \div 3=6$  cm  
Also,  $GU=SN$  ( $\because$  Opposite sides of parallelogram are equal)  
 $\Rightarrow 3y-1=26$   
 $\Rightarrow 3y=26+1$   
 $\Rightarrow 3y=27$   
 $\Rightarrow y=27 \div 3=9$  cm  
Hence,  $x=6$  cm and  $y=9$  cm.

Q.75. The following figure RUNS is a parallelogram, Find  $x$  and  $y$ . (Length are in cm)

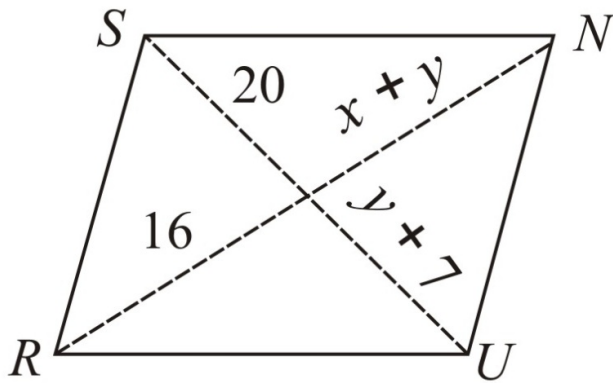

**Solution:** Given parallelogram is:

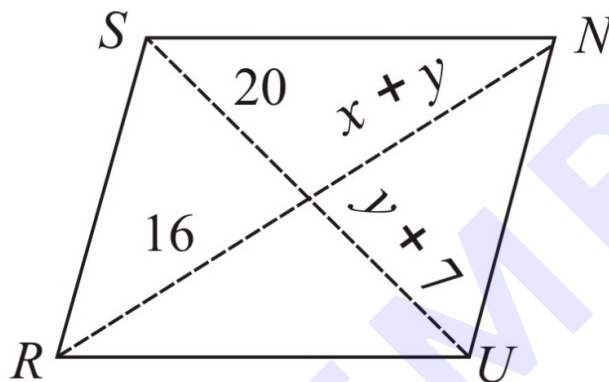

In parallelogram RUNS,

$y + 7 = 20$  ( $\because$  Diagonals of a parallelogram bisect each other)  
 $\Rightarrow y = 20 - 7 = 13$  cm  
 Similarly,  $x + y = 16$   
 $\Rightarrow x + 13 = 16$   
 $\Rightarrow x = 16 - 13$   
 $\Rightarrow x = 3$  cm  
 Hence,  $x = 3$  cm and  $y = 13$  cm.

Q.76. In the figure, both RISK and CLUE are parallelograms. Find the value of  $x$ .

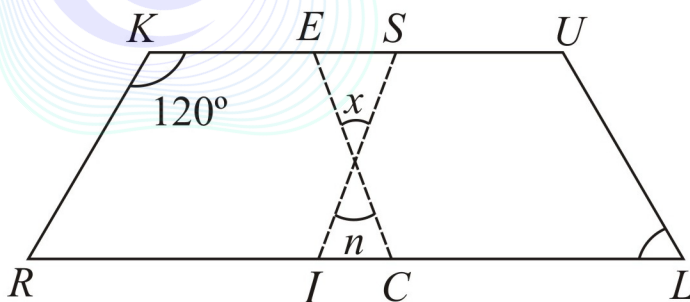

**Solution:**

Given: RISK and CLUE are parallelograms.

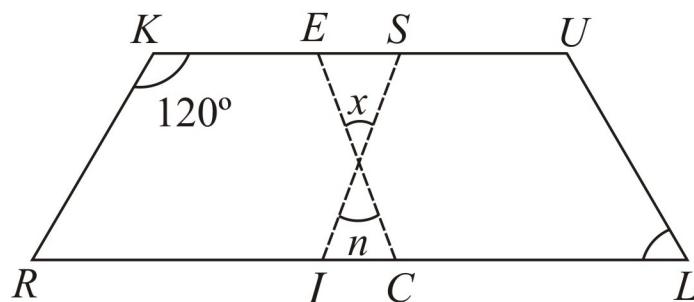
Let, the angle vertically opposite to  $x$  be  $n$ .

In parallelogram RISK,

 $\angle RIS = \angle K = 120^\circ$  ( $\because$  Opposite angles of a parallelogram are equal) $\angle SIC + \angle RIS = 180^\circ$  ( $\because$  Sum of linear pair of angle is  $180^\circ$ )

$$\Rightarrow \angle SIC + 120^\circ = 180^\circ$$

$$\Rightarrow \angle SIC = 180^\circ - 120^\circ = 60^\circ$$

and  $\angle ECI = \angle L = 70^\circ$  ( $\because$  Corresponding angles are equal) $\angle SIC + n + \angle ECI = 180^\circ$  (By Angle sum property of a triangle)

$$\Rightarrow 60^\circ + n + 70^\circ = 180^\circ$$

$$\Rightarrow 130^\circ + n = 180^\circ$$

$$\Rightarrow n = 180^\circ - 130^\circ = 50^\circ$$

also  $x = n = 50^\circ$  ( $\because$  Vertically opposite angles are equal)Hence, the value of  $x$  is  $50^\circ$ .

**Try these**

Q.1. What is the sum of the measure of its exterior angles  $x, y, z, p, q, r$ ? Write the answer in degrees.

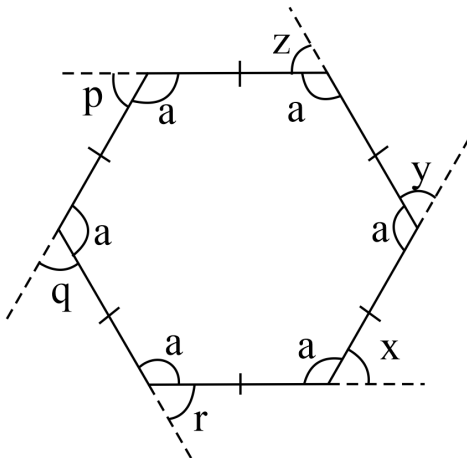

360

**Solution:** In a regular polygon all the sides of the polygon are equal.

Similarly, a regular hexagon is a polygon with six equal sides and angles.

Formula to find the exterior angle of a polygon is,  $360^\circ \div \text{number of sides} \Rightarrow 360^\circ \div 6$  The measure of each angle of a regular hexagon  $= 360^\circ \div 6 = 60^\circ$  We know, all the exterior angles of a regular hexagon are equal.

So,  $x = y = z = p = q = r = 60^\circ \Rightarrow x + y + z + p + q + r = 60^\circ + 60^\circ + 60^\circ + 60^\circ + 60^\circ + 60^\circ = 360^\circ$  Hence, the sum of the measure of the all exterior angles of a given polygon is  $360^\circ$ .

Q.2. Is  $x = y = z = p = q = r$ ? Why?

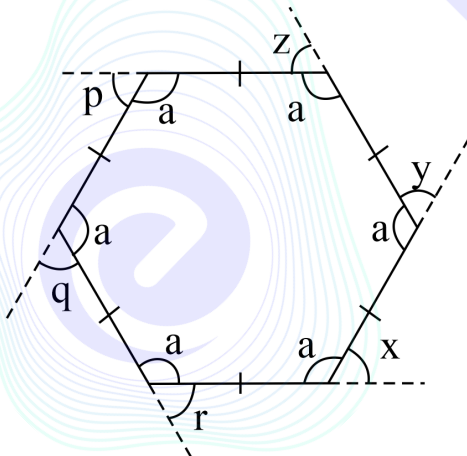

**Solution:** In a regular polygon all the sides are equal.

Similarly, a regular hexagon is a polygon with six equal sides and equal angles.

Formula to find the exterior angle of a polygon is  $= 360^\circ \div \text{number of sides}$  Here the exterior angles are  $x, y, z, p, q$  and  $r$  The measure of each exterior angle of a regular hexagon  $= 360^\circ \div 6 = 60^\circ$

So,  $x = y = z = p = q = r = 60^\circ$ , because all the exterior angles of a regular hexagon are equal.

Hence,  $x = y = z = p = q = r = 60^\circ$ .

Q.3. What is the measure of each exterior angle? Write the answer in degrees.

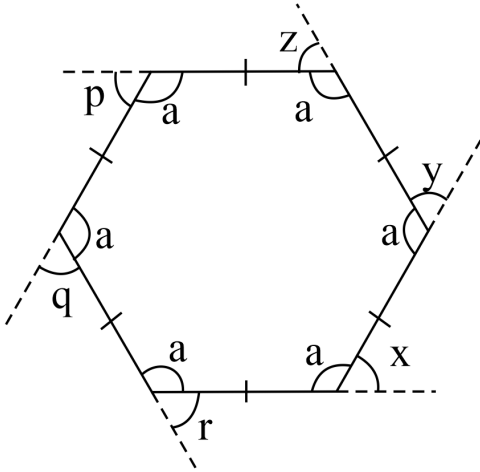

60

**Solution:**

In a regular polygon all the sides of the polygon are equal.

Similarly, a regular hexagon is a polygon with six equal sides and angles.

Formula to find the exterior angle of a polygon is  $\frac{360^\circ}{\text{Number of sides}}$  The measure of each exterior angle of a regular hexagon  $= \frac{360^\circ}{6} = 60^\circ$  We know, all the exterior angles of a regular hexagon are equal. So,  $x=y=z=p=q=r=60^\circ$  Hence, the measure of each exterior angle of a regular hexagon is  $60^\circ$ .

Q.4. What is the measure of each interior angle? Write the answer in degrees.

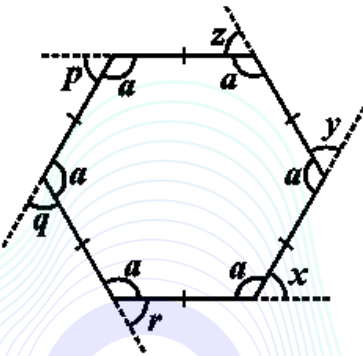

120

**Solution:**

In a regular polygon all the sides of the polygon are equal.

Similarly, a regular hexagon is a polygon with six equal sides and angles.

Formula to find the interior angle of a polygon is,  $\frac{n-2}{n} \times 180^\circ$  Where,  $n$ =number of sides Here,  $n=6$   
 $\Rightarrow \frac{6-2}{6} \times 180^\circ \Rightarrow \frac{4}{6} \times 180^\circ \Rightarrow 4 \times 30^\circ \Rightarrow 120^\circ$  Hence, the measure of each interior angle of a regular hexagon is  $120^\circ$ .



EMBIBE